

# AMW 439/WH

12NC: 858743901940

GTIN (EAN) code: 8003437394874

Whirlpool

SENSING THE DIFFERENCE

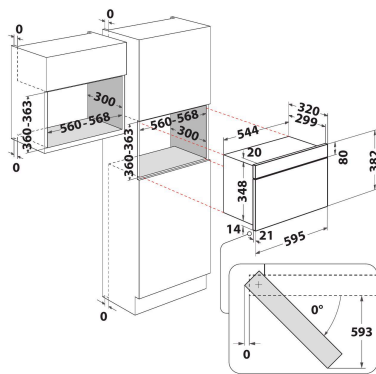

## MAIN FEATURES

|                                       |                   |
|---------------------------------------|-------------------|
| Product group                         | Microwave         |
| Commercial code                       | AMW 439/WH        |
| Main colour of product                | White             |
| Type of micro-wave oven               | MW+Grill function |
| Construction type                     | Built-in          |
| Type of control                       | Electronic        |
| Type of control settings              | LED               |
| Additional cooking method Grill       | Ano               |
| Crisp                                 | Ano               |
| Steam                                 | Ne                |
| Additional cooking method Fan cooking | Ne                |
| Clock                                 | Ano               |
| Automatic programmes                  | Ne                |
| Height of the product                 | 382               |
| Width of the product                  | 595               |
| Depth of the product                  | 320               |
| Minimum niche height                  | 360               |
| Minimum niche width                   | 556               |
| Niche depth                           | 300               |
| Net weight (kg)                       | 21                |
| Cavity capacity (l)                   | 22                |
| Turntable                             | Ano               |
| Turntable diameter (mm)               | 250               |
| Integrated Cleaning system            | Ne                |

## TECHNICAL FEATURES

|   |            |
|---|------------|
| Current (A)                               | 10         |
| Voltage (V)                               | 230        |
| Frequency (Hz)                            | 50         |
| Length of Electrical Supply Cord (cm)     | 135        |
| Plug type                                 | Schuko     |
| Timer                                     | Ano        |
| Grill power (W)                           | 700        |
| Type of grill                             | Quartz     |
| Cavity material                           | Painted    |
| Interior light                            | Ano        |
| Additional cooking method Grill           | Ano        |
| Position of interior lights of the cavity | Right side |

## ENERGETICKÝ ŠTÍTEK

|                                  |     |
|----------------------------------|-----|
| 6th Sense / Dynamic Intelligence | Ne  |
| Number of power levels           | 4   |
| Maximum micro-wave power (W)     | 750 |
| Bread Defrost                    | Ne  |
| Jet Defrost                      | Ano |
| Jet Start                        | Ano |