

WSIO 3T125 6PE X

12NC: 869991616410

GTIN (EAN) code: 8003437232923

Whirlpool

SENSING THE DIFFERENCE

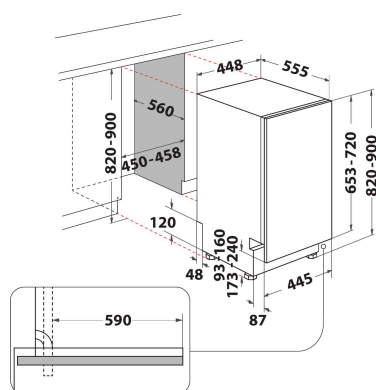

MAIN FEATURES

Construction type	Built-in
Installation type	Plne vestavná
Type of control	Electronic
Type of control settings	-
Removable work top	Ne
Main colour of product	Nerez
Electrical connection rating (W)	1900
Current (A)	10
Voltage (V)	220-240
Frequency (Hz)	50
Length of Electrical Supply Cord (cm)	130
Plug type	Schuko
Length inlet hose (cm)	155
Ledningslængde (cm)	150
Adjustable feet	Yes - all from front
Height of the product	820
Width of the product	448
Depth of the product	555
Minimum niche height	820
Maximum niche height	900
Minimum niche width	450
Maximum niche width	600
Niche depth	560
Net weight (kg)	29.6
Gross weight (kg)	31.6

TECHNICAL FEATURES

Automatic programmes	Ano
Maximum temperature for water intake (°C)	60
Start delay options	Continuous
Start delay time max. (h)	12
Progress indicator	-
Digital countdown indicator	Ano
Salt light indicator	Ano
Rinse aid light indicator	Ano
Safety device	N/A
Adjustable upper basket	Ano
Largest loadable dish upper basket (cm)	0
Largest loadable dish lower basket (cm)	0
Maximum number of place settings (EU 2017/1369)	10
Column installation	Ne

ENERGETICKÝ ŠTÍTEK

Energy Efficiency Class (Regulation (EU) 2017/1369)	E
Energy Consumption for 100 cycles Eco Programme (EU 2017/1369)	76
Power consumption in standby mode (Psm) (EU 2017/1369)	0,50
Power consumption in off-mode (Po) (EU 2017/1369)	0,00
The water consumption of the eco programme in liters per cycle (EU 2017/1369)	6,0
Airborne acoustical noise emissions (EU 2017/1369)	45
Airborne acoustical noise emission class (EU 2017/1369)	C
Programme duration in HMM (EU 2017/1369)	3:50